

---

# **TII492 Intelligent Transport Systems (ITS) - Equipment Supply and Installation Framework - Generation 2 - Lot 2**

**Volume A: Works Requirements**

**Part 3: Technical Specification  
Section 2: Advanced Matrix Indicators**

**June 26**

## Contents Table

<b>1.</b>	<b>INTRODUCTION.....</b>	<b>1</b>
1.1	Introduction.....	1
1.2	Scope of Works.....	1
<b>2.</b>	<b>SIGNAGE REQUIREMENTS.....</b>	<b>3</b>
2.1	General Requirements.....	3
2.2	Design.....	4
<b>3.</b>	<b>SUPPLY.....</b>	<b>15</b>
3.1	General Requirements.....	15
<b>4.</b>	<b>INSTALL.....</b>	<b>16</b>
4.1	Location.....	16
4.2	Mounting Requirements.....	16
4.3	Co-ordination.....	18
4.4	Integration.....	18
4.5	SAT & Commissioning.....	19
<b>5.</b>	<b>SLIP ROAD SIGNAGE (SRS) AMIs.....</b>	<b>20</b>
5.1	General requirements.....	20
5.2	Design.....	20
5.3	Install.....	22
5.4	Mounting Requirements.....	22

# 1. INTRODUCTION

## 1.1 Introduction

This specification defines the requirements for the supply, installation, testing and commissioning of Advanced Matrix Indicators (AMI). The AMI shall be installed on gantries and verge mounted posts for Slip Road Signage (SRS) sites, on the road network.

Installed Advanced Matrix Indicators shall be capable of displaying lane specific information to road users. AMI shall be capable of displaying information transmitted by the MOCC.

The Contractor shall design, supply and install AMI signage in accordance with this specification at the locations detailed in the Works Requirements.

This specification outlines the following for the AMI:

- Scope of Works;
- Signage Requirements;
- Design Requirements;
- Supply Requirements;
- Install Requirements.

## 1.2 Scope of Works

The scope of works includes but is not limited to the following:

- The Contractor shall design all AMI in accordance with the requirements of this specification.
- The Contractor shall supply and install AMI on gantries and post structures including all necessary mounting bracketry, power connections and communications interfaces in accordance with the requirements of this specification.
- The Contractor shall support the integration of the AMI outstation controller with the Network Intelligence and Management System (NIMS), Asset and Fault Management System (AFMS) and other Associated Services in accordance with the requirements of this specification and Volume A - Part 4: Testing and Commissioning Specification.
- The Contractor shall undertake all testing and commissioning of all AMI in accordance with the requirements of this specification and Volume A - Part 4: Testing and Commissioning Specification.

The Contractor shall ensure that all works carried out under this Contract shall comply with the recommendations and requirements set out in the current edition of the following:

- EN 12966:2014+A1:2018 Standards Publication for Variable Message Signs (VMS);
- DN-ITS-03029 Traffic Control and Communications Infrastructure Design;
- DN-ITS-03037 The Use of Variable Message Signs on All-Purpose and Motorway Roads;

- DN-ITS-03021 - VMS Standard;
- DN-TSM-03083 - VMS Policy;
- DN-TSM-03084 - VMS Messaging Guidelines;
- Environmental Tests for Motorway Communications Equipment and Portable and Permanent Road Traffic Control Equipment TR2130;
- Safety, Health and Welfare at Work (Construction) Regulations 2013;
- Safety, Health and Welfare at Work (General Application) Regulations 2007;
- All appropriate European Union (EU) Health and Safety legislation;
- EU Waste Electrical and Electronic Equipment Regulations 2014; and,
- All publications as detailed within these requirements.

## **2. SIGNAGE REQUIREMENTS**

### **2.1 General Requirements**

The AMI shall consist of a display panel, with associated equipment and an outstation controller.

AMI display panels shall be used to display lane status information, like the Red 'X' for a lane closure, the speed limit or other information.

The AMIs shall be installed on gantries above each running lane or on verge mounted posts at SRS sites.

A pair of AMI display panels shall display speed limits and pictograms at SRS sites on each verge of the junction on-ramps.

All the functional and performance requirements in this specification shall apply to the SRS sites, unless otherwise stated otherwise.

SRS AMI specific requirements are included in Chapter 5 of this specification.

The purpose of the AMI is to contribute to the safe and efficient use of the road by providing clear and concise information to the motorists in a reliable and consistent manner.

The Contractor shall ensure that all equipment supplied shall have a design life of not less than 15 years within the motorway environment. The supplier shall provide warranties ensuring that spares will be available for a period of 10 years from the date of purchase.

The Contractor shall be responsible for the installation of all equipment, mounting arrangements and power supply equipment.

The Contractor shall ensure that all the interfaces and elements used throughout comply with current industry standards for AMIs.

All AMI supplied and installed under this Contract shall comply with the requirements of relevant European Directives and Irish legislation, in particular those related to Product Liability, Safety, Electro Magnetic Compatibility, Waste Management and Restrictions on the use of Hazardous Substances, current at the Contract Date.

All works carried out under this Contract shall comply with the requirements and recommendations set out in current editions of the various standards and publications referenced in this specification. Where there is any conflict between Irish and other standards, the Irish standards shall take precedence.

All structural design and installation work associated with the supply of AMI supporting structures and enclosures shall comply with DN-STR-03010, EN IEC 61439, Eurocodes and, other relevant standards.

The Contractor shall submit all technical literature, information and documentation for AMI in accordance with the Specification.

The maximum weight of the AMI shall be 200kg.

The maximum weight of the SRS AMI shall be 60kg.

The supplier shall provide warranties ensuring that spares will be available for a period of 10 years from the date of purchase.

The Contractor shall provide a warranty of 1 year following substantial completion of the works. As part of this warranty, the Contractor shall agree to repair or replace all equipment that are found to be faulting in the warranty period. The Contractor shall provide technical support to the ITS Maintenance Contractor during the warranty period.

## **2.2 Design**

The Contractor shall comply with all the requirements of this section.

### **2.2.1 Optical**

#### **2.2.1.1 Functional Requirements**

The AMI display panel shall receive and action commands from the AMI outstation controller.

The AMI display panel shall monitor and report any fault arising and being cleared to the AMI outstation controller and the AMI outstation controller shall transmit such fault status to Associated Services in accordance the communication requirements.

The AMI shall be compatible with the electrical, communications and structural interfaces provided and shall be supplied new and manufactured from new apparatus.

The AMI shall be designed in accordance with the latest adopted version of EN 12966 Standards Publication for Variable Message Signs (VMS), TR 1100 and TR 2043.

The AMI shall be designed in accordance with European Committee for Electrotechnical Standardisation (CENELEC) EN 50293:2012.

Removal or failure of any LED module shall not affect the operation of any other LED module or sign component or the structural integrity of any part of the AMI.

The AMI display panel shall be of full matrix and full colour capability and shall be comprised of LEDs that shall be capable of displaying red, green, blue, white or yellow colour.

The AMI display panel shall have a high-resolution display with a matrix comprised of pixels. Each pixel pitch (distance between pixel centres) shall be 20mm. If an alternative matrix is proposed, this shall be subject to the discretion and approval of the Employer's Representative.

The AMI display panel LED pixels shall have colour performance in accordance with the latest EN 12966 Standards Publication for VMS.

Under all conditions, the AMI display panel LED pixels shall have a uniform colour balance and be maintained at all luminance levels when different colours are on at the same time, in order to avoid a blooming effect.

Under all conditions, the AMI display panel shall emit the respective wavelengths of light as specified in the performance classes within this specification as per EN 12966.

Under all conditions, the various AMI display panel LED bins shall be distributed evenly throughout the sign display and shall be consistent from pixel to pixel. Random distribution of the LED bins shall not be permitted.

Under all conditions, the AMI display panel LED display face shall have colour uniformity and consistency as specified in EN 12966.

The AMI display panel matrix shall display continuous, uniform and unbroken Aspects, visible to all motorists.

The AMI display panel character sets, fonts, size and minimum dimensions shall be in accordance with the latest version of Traffic Signs Manual, Chapter 5 and Tables N.1, N.2 and N.3 of EN 12966 for Size Range E.

The AMI display panel shall be capable of displaying any speed limits from 10-120 km/h in 5 km/h intervals.

The AMI display panel shall be capable of displaying four full colour virtual flashing lanterns.

- Each virtual flashing lantern shall be circular with diameter of approximately 125mm.
- Each pair of virtual flashing lanterns shall alternately flash top and bottom.

The AMI display panel shall be capable of displaying lanterns which shall not flash when displaying speed limits.

The AMI display panel shall be capable of displaying numerical characters of two or three digits.

- The height of the numerical character shall be at least 400mm.

The AMI display panel shall have the option of displaying the characters 'km/h' below the numerical characters.

- The minimum height of the 'km/h' characters shall be 120mm and they shall be centred below the numerals and within the Red Ring.

The AMI display panel shall display Aspects (together with/without a steady-illuminated Red Ring and/or flashing lanterns) when requested by the AMI outstation controller.

- The Red Ring shall have a maximum 1300mm outer diameter.
- There shall be at least 50mm space between the numerical character and the Red Ring.

The option of alternating Aspects to be displayed shall be allowed on the AMI display panel.

Figure 1 provides a representation of the gantry mounted AMI display panel.

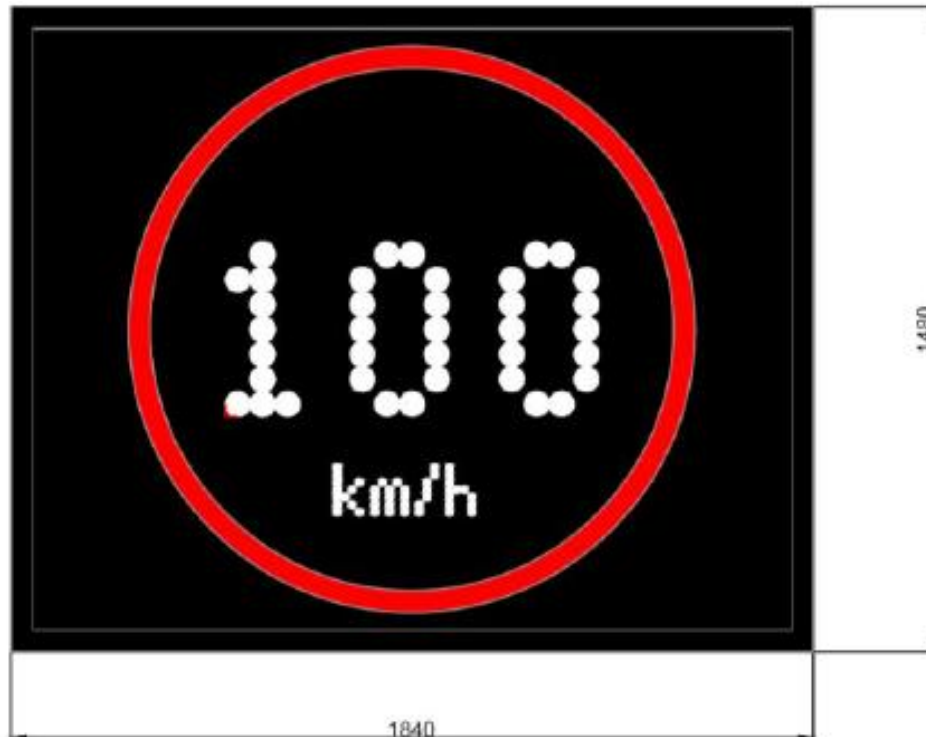

**Figure 1 Gantry mounted AMI Display Area and General Dimension**

The AMI display panel shall be able to display:

- red 'X' to indicate closure of lane with side-to-side flashing lanterns.
- wickets to indicate open/closed lanes with up and down flashing lanterns.
- yellow arrow to the left with up and down flashing lanterns.
- yellow arrow to the right with up and down flashing lanterns.
- with minimum height 600mm by 600mm width.
- symbols and shall have at least 50mm space from all sides of the AMI. The AMI display panel shall be able to display static symbols.

The AMI display overall panel dimensions shall not exceed 1840mm x 1480mm as shown in Figure 1. The minimum dimension shall not be less than 1720mm x 1325mm.

The Contractor shall undertake design calculations for the optimal dimensions of the AMI and submit it to the Employer's Representative for approval.

The AMI shall be equipped with an Ambient Light Monitoring (ALM) unit or Light Sensor unit to measure the external illumination from all directions and to provide signal inputs to the AMI outstation controller to adjust the display intensity.

Adjustment of display intensity shall compensate for all lighting conditions including direct sunlight and darkness.

The display intensity of the AMI display panel shall vary in accordance with the ambient light level but shall have the option to be overridden by the MOCC operator.

All parts of the AMI shall be designed and manufactured in a modular fashion to facilitate simple maintenance and enhancement activities.

All parts shall be manufactured from suitable non-corrodible material. The arrangements for the AMI shall provide protection against bimetallic corrosion at the contact points with the gantry or post structure.

All side and rear facing surfaces of the AMI shall be Grey 18B21 BS4800 (non-reflective) to achieve the required design life and/or reduce solar gain.

All front facing surface of the AMI shall be matt black in colour.

All unpainted surfaces of the AMI shall be dulled.

All AMI finishes shall give a high-quality consistent appearance and retain their colour for the design life of the equipment.

**2.2.1.2 Performance Requirements**

All AMI shall meet the requirements of European Harmonised Standards EN 12966 in the performance classes specified in Table 1 below:

The AMI shall maintain its optical performance characteristics to the stated performance classes of the latest EN 12966 Standards Publication for VMS, over the expected operational life, based on an anticipated minimum overall daily 33% duty cycle.

**Table 1 EN 12966 Performance Classes**

EN 12966 Performance Classes		
Visual Performance	Colour	C2
	Luminance (La)	L3
	Luminance Ratio (LR)	R3
	Beam Width	B3
Physical Performance	Temperature	T1
	Ingress Protection	IP56
	Corrosion	D2/SP2
	Temporary deflections caused by wind load	WL8
	Temporary deflections caused by bending	TDB1

The AMI display panel shall provide a display which is free from reflections from likely external light sources (e.g. vehicle headlamps; street lighting).

The AMI display panel shall be clearly legible from all lanes of the motorway from distances as defined in EN 12966 at all times and under all lighting conditions. The Contractor shall undertake the calculation to confirm the final legibility distances as per EN12966.

The AMI display panel shall meet the performance classes of the latest EN 12966 Standards Publication for VMS for all defined colours.

All AMI installed shall be capable of receiving commands from the AMI outstation controller for the setting of Aspects with any associated lanterns displays, at a frequency of every five seconds.

All AMI display panels shall be capable of performing all background testing and monitoring procedures constantly to enable all control source messages to be responded correctly.

All AMI display panels shall be capable of responding to requests from ALM unit at a maximum frequency of once every five seconds.

All AMI shall be capable of achieving the requirements with a minimum of 70% spare capacity in both processor cycles and memory, to allow for future upgrades.

The AMI shall not radiate electromagnetic signals that affect other electronic devices.

The performance of AMI shall not be affected by any presence of ambient radio signals and magnetic or electromagnetic interference.

Under all conditions, the AMI display panel LED shall have a minimum lifetime of 100,000 hours while maintaining 70% of their original brightness.

All equipment supplied shall have a Mean Time Between Failures (MTBF) in excess of four years.

AMI components shall operate at a minimum temperature of -15°C to +60°C and at a relative humidity of 0 to 95%, non-condensing.

## **2.2.2 AMI Outstation Controller**

The Contractor shall comply with all the requirements of this section.

### **2.2.2.1 Functional Requirements**

The AMI outstation controller shall switch off AMI display panels when performance falls below the requirements in this specification.

The AMI outstation controller shall comply with the requirements of this specification.

The AMI outstation controller shall have the capability of storing:

- at least 100 changeable and 50 permanent pre-defined aspects with a unique code;
- at least 128 volatile messages;
- at least 1000 events in the event log file;
- schedules; and,
- other necessary files for controller operation.

The AMI outstation controller shall have the capability of receiving transmitted files from Associated Services that update the files stored in the AMI outstation controller.

The codes to implement Aspects on the AMI display panel shall be transmitted by Associated Service in accordance with the communication requirements.

The AMI outstation controller shall have a front panel user interface graphical LCD and keypad/keyboard for direct operation and diagnostics. The functionality of the front panel may be provided via laptop (engineer's terminal) as an option.

The access to the AMI outstation controller front panel user interface graphical LCD and keypad/keyboard, where available, shall be password protected.

The full range of functionality available through the AMI outstation controller front panel user interface graphical LCD and keypad/keyboard shall also be available via diagnostics software available for installation on a maintenance laptop (engineer's terminal) and connected to the maintenance port on the AMI outstation controller or remotely via the communications network.

The AMI outstation controller shall be capable of monitoring the status of the sign controller, including the status of all sensors and a RGB representation of the Aspect visible on the AMI display panel.

The AMI outstation controller shall be capable of performing diagnostics testing of various system components, including pixels, power systems and sensors and also manage Aspects that are stored in memory.

The AMI outstation controller shall be capable of blanking the AMI display panel and start and stop the schedule.

The AMI outstation controller shall have an internal clock and shall use Network Time Protocol (NTP) to synchronise the time and date with Associated Services.

The AMI outstation controller shall be capable of implementing Aspects on AMI display panels on a time-based schedule determined by the Associated Services.

The AMI outstation controller shall be capable of configuring AMI display panel parameters, including display size and colour technology and brightness mode.

The AMI outstation controller shall be capable of configuring communications and NTCIP settings.

The AMI outstation controller shall have a minimum of two NTCIP-compliant Ethernet ports with RJ45 connectors.

These ports shall be used to connect to local engineer's terminal, software updates and communication with the Associated Services.

The AMI outstation controller shall have a power switch to turn the controller on and off and an LED "on" indicator.

The AMI outstation controller shall have a local/remote switch with an LED indicator that places the controller in local mode such that it can be controlled from the front panel user interface graphical LCD and keypad/keyboard and/or local engineer's terminal instead of via the primary communications channel.

The AMI outstation controller shall have a reset switch to quickly restart the controller.

The AMI outstation controller shall have an LED "Active" indicator that blinks when the controller is operating.

The AMI outstation controller shall have an LED to indicate when any of the NTCIP communications channels are active.

The AMI outstation controller shall have the capability to play volatile messages.

The AMI outstation controller shall contain AMI-specific control firmware (embedded software) that monitors all external and internal sensors and communication inputs.

The AMI outstation controller control firmware shall control the display modules as directed by the Associated Services and the front panel interface.

The AMI outstation controller shall monitor the status of the sign and have a representation of the sign display face.

The AMI outstation controller shall control the Aspects displayed on AMI display panel which shall be:

- Static Aspects with or without flashing lanterns, and;
- Alternating Aspects with or without flashing lanterns.

The AMI outstation controller shall set the Aspect displayed on the AMI display panel by one of the following ways:

- By a command issued automatically by the Associated Services;
- By a command issued by an operator through the Associated Services.
- By a command issued by an operator through the local communication interface on the AMI outstation controller; and,
- Pre-set messages; those are displayed in certain events, such as communication failure with Associated Services.

The AMI outstation controller shall sequence the operation of the virtual flashing lanterns such that they are synchronised for all sets of AMIs.

The AMI outstation controller shall provide confirmation to the Associated Services that a message or command was received correctly.

The Aspect shall remain on the AMI display panel until the AMI outstation controller receives a command to change the message or blank the sign.

The AMI outstation controller shall support as a minimum, the ability to display alpha numeric characters (letters and numbers), punctuation and different character font styles.

The AMI outstation controller shall support as a minimum, the ability to align the displayed text and symbols horizontally and vertically.

The AMI outstation controller shall support as a minimum, the ability to adjust the spacing of Aspects horizontally or vertically.

The AMI outstation controller shall support as a minimum, the ability to display alternating aspects.

The AMI outstation controller shall support the ability to display Aspects of any size up to the size of the entire AMI display matrix.

The Contractor shall provide the AMI outstation controller with all the symbols and fonts preinstalled. The AMI outstation controller shall support changing or replacing these from the Associated Services.

The outstation controller shall be capable of receiving and displaying any bitmap from the Associated Services.

The AMI outstation controller shall select brightness mode of operation. The brightness of the AMI display panels shall be controlled by ambient light over a minimum of 16 light levels with 16 being the highest light level.

The AMI outstation controller shall monitor the ALM units constantly and adjust the LED to the level of display matrix intensity, so the Aspect on the AMI display panel is legible.

The AMI outstation controller shall set the AMI display to a default light level of 10 in case of any faults with the ALM.

The AMI outstation controller shall automatically shut down the AMI display panel LED modules to prevent damage to the LED if the measured on-board temperature exceeds a maximum threshold temperature.

The maximum on-board threshold temperature shall be configurable and shall have a default factory setting.

The AMI outstation controller shall be capable of automatically informing Associated Services if a fault arises or being cleared, or failure occurs on AMI components and systems.

The AMI outstation controller shall detect failures in the communications link with the Associated Services or failure of the Associated Services and shall maintain the Aspects displayed on the AMI display panels for a pre-set duration after which the AMI display panels shall default to a blank state if the failure has not been resolved.

The AMI outstation controller shall enable the adjustment of the pre-set duration after which the AMI display panels shall default to a blank state if a failure has not been resolved.

Each AMI outstation controller shall connect to minimum of eight AMI display panels. This shall also include connecting to remote SRS AMI.

The AMI outstation controller shall be capable of controlling the AMI display panels connected to it individually or as a group.

The AMI outstation controller shall be capable of controlling a minimum of two AMI display panels as a group.

The AMI outstation controller shall be capable of controlling at least four groups of AMI display panels connected to it.

The AMI outstation controller shall perform the safe changing of the speed limit by sequencing the change from the current speed limit, by a pre-set speed value step change for a pre-set duration (e.g. increase/decrease 20kph every 6 seconds), until the required speed limit is displayed.

The AMI outstation controller shall perform the safe setting of the Red X by sequencing the decrease from the current speed limit to the minimum speed limit and then sequencing through any pre-set aspects for a pre-set duration until the Red X is displayed.

The AMI outstation controller shall enable the adjustment of the pre-set speed value step change and pre-set duration sequencing parameters to enable the safe changing of the speed limit and setting of the Red X.

The AMI outstation controller shall provide confirmation to the Associated Services that the safe changing of the speed limit or setting of the Red X was implemented correctly.

The AMI outstation controller shall connect to gantry mounted AMI display panels via a Cable Marshalling Unit (CMU).

The CMU shall be installed in an enclosure suitable for installation in an outdoor environment. The CMU enclosure is to be wall mounted type insulated modular enclosure with transparent cover, IP66 rated, resistant to heat, shocks, atmospheric agents and U.V. rays with grey RAL 7035 base and clamped to the existing structure. No welding or drilling to the existing structure is permitted. The dimensions of the CMU enclosure shall not exceed 500mm (W) by 500mm (H) by 300mm (D).

The dimensions of the CMU shall not exceed 500mm (W) by 500mm (H) by 300mm (D).

The AMI outstation controller shall support all flash on times from 5 tenths of a second to 100 tenths of a second in 5 tenths of a second increments for all virtual flashing lanterns.

The AMI outstation controller shall occupy a maximum rack height of 4U.

### **2.2.2.2 Performance Requirements**

All AMI outstation controller components shall operate at a minimum temperature of -15°C to +60°C and at a relative humidity of 0 to 95%, non-condensing.

### **2.2.3 Ambient Light Monitoring (ALM)**

The Contractor shall comply with all the requirements of this section.

#### **2.2.3.1 Functional Requirements**

The ALM equipment shall incorporate two independent light sensors and be designed to measure the ambient light level in all directions from the vertical to the horizon.

The ALM equipment shall be positioned in accordance with EN 12966:2014+A1:2018 and must operate independently to detect illuminance from all directions.

The ALM equipment must comply with the luminance requirements as outlined in EN 12966:2014+A1:2018.

The ALM equipment shall be designed to prevent the build-up of snow affecting their operation.

The AMI and flasher luminance shall be determined from the light sensor reading the highest ambient light level.

#### **2.2.3.2 Performance Requirements**

The ALM equipment shall cover the whole range of light levels from full daylight to darkness within their operating ranges, with an accuracy of  $\pm 2$  Lux or 5%.

The ALM equipment shall be calibrated to cover the full range of light levels from bright sunlight to darkness with accuracy within  $\pm 2$  Lux,  $\pm 5\%$ .

All sets of AMIs that are on the same gantry, shall display the same luminance at all times.

### **2.2.4 Enclosure & Ventilation**

The Contractor shall comply with all the requirements of this section.

#### **2.2.3.3 Functional Requirement**

All equipment installed on the gantry and on posts shall have a weatherproof enclosure. The Contractor shall ensure that the size and the opening of the enclosure fits the gantry / posts structural arrangements.

The AMI display enclosure shall be corrosion resistant in accordance with EN 12899-1:2007 and environmentally controlled. The material used shall conform to the EN IEC 62208:2023 Empty enclosures for low-voltage switchgear and controlgear assemblies - General requirements and European Standards for the appropriate material.

The AMI display enclosure shall protect internal components from rain, ice, dust and corrosion.

All external equipment enclosures of the AMI shall be compliant with Category IP 56 of EN 60529 as a minimum.

The AMI and all associated equipment and enclosures shall be EN IEC 62368-1:2018 listed by accredited safety laboratories and shall bear the CE mark on the outside of the AMI display enclosure.

Enclosures manufactured from aluminium or steel shall comply with EN 1090-2:2018+A1:2024 Execution of steel structures and aluminium structures.

The AMI display enclosure shall contain an electronically controlled ventilation system to prevent damage from heating resulting from operation outside of the equipment's specifications.

The ventilation system shall consist of one or more air intake ports which shall be located near the top of all AMI display rear wall. One or more ball bearing-type fans shall be mounted at each intake port.

The ball bearing-type fans shall positively pressure the AMI display enclosure.

The ball bearing-type fans shall be removable and replaceable from inside the AMI display enclosure.

Each ventilation fan shall contain a sensor to monitor its rotational speed and shall be reported to the AMI controller.

The ventilation system shall move air across the rear of the LED modules so that heat is dissipated from the LED. The airflow shall move from the top of the AMI display enclosure towards the bottom to move heat away from the modules.

Each exhaust port shall be located near the bottom of the rear AMI display enclosure wall. One exhaust port shall be provided for each air intake port.

All AMI display enclosures shall be designed to allow dispersal of heat generated during operation.

#### **2.2.3.4 Performance Requirements**

The ventilation system shall keep the AMI display enclosure internal air temperature lower than +60° C, when the outdoor ambient temperature is +46° C or less.

AMI enclosures shall be designed to retain full structural integrity for 30 years without maintenance.

AMI enclosures shall comply with class WL8 in EN 12899-1.

The deflection class for the enclosures due to temporary loads shall be TDB1 in accordance with EN 12899-1.

The deflection class for the enclosures due to dynamic snow loads shall be DSL4 in accordance with EN 12899-1.

All other loads and combinations for the enclosures shall be calculated in accordance with EN 12966.

## **2.2.4 Communications and Power**

The Contractor shall comply with all the requirements of this section.

### **2.2.4.1 Functional Requirements**

The AMI outstation controller shall use embedded National Transportation Communication for ITS Protocol (NTCIP) protocol to communicate with NIMS, in accordance with NTCIP 1203 version v04.

The Contractor shall note that the power cable that provides current to AMI has been designed to accommodate a maximum load of 350VA and therefore the power consumption of the AMI supplied shall not exceed 350VA.

### **2.2.4.2 Performance Requirements**

Commands from NIMS shall be implemented on the AMI display panel within 1 second of the commands being received by the AMI outstation controller.

The conformation message, that the NIMS command has been implemented on the AMI display panel, shall be transmitted to NIMS from the AMI outstation controller within 1 second.

The AMI outstation controller shall transmit fault status messages to the Associated Services within 1 second of the fault occurring or the fault being cleared.

## **2.2.5 Certifications**

The Contractor shall comply with all the requirements of this section.

### **2.2.5.1 Functional Requirements**

The Contractor shall analyse the AMI structural design and shall certify that the AMI meets EN12899 compliance.

The Contractor shall certify that the AMI will withstand the temporary effects of being lifted by the pick points provided and will comply with the applicable requirements of EN12899.

The Contractor shall analyse the complete AMI structural design. The structural analysis must include, but shall not be limited to:

- Sign housing;
- The quantity and type of lifting points to be provided;
- The quantity and type of mounting brackets to be provided;
- The quantity and type of hardware (nuts, bolts, washers) used to attach the mounting brackets;
- Verification that no dissimilar metals problem will exist and/or affect the structural integrity of the VMS-to-bracket attachment points; and,
- A recommendation of the number of attachment points, as well as the attachment locations that the Contractor should use when mounting the AMI display panel to its support structure.

## **3. SUPPLY**

### **3.1 General Requirements**

All equipment shall be supplied new and manufactured from new components.

The Contractor shall supply and install any additional shock and vibration interface the AMI to ensure that they are not affected by the vibration and wind caused by the motorway environment.

The Contractor shall submit all the materials, software and services necessary to install all AMI outstation controllers, auxiliary control panels and associated equipment that comply with the functional requirements of this specification.

The Contractor shall supply all brackets and fixtures required to mount the equipment onto the existing gantries and verge mounted posts.

## 4. INSTALL

### 4.1 Location

The Contractor shall comply with all the requirements of this section.

The Contractor shall install AMI's onto existing and new AMI frames.

The AMI shall be capable of being fully maintained and repaired safely whilst remaining installed on its gantry mounting structure, without the need for lane closures.

The Contractor shall confirm proposed AMI can fit on the allocation frame structure on gantry whilst ensuring that maintenance doors of the proposed sign can be accessed from inside the gantry.

The Contractor shall ensure that the AMI shall be equipped with door(s) that open to an angle of 90 degrees and be fitted with automatic hold open stays locking at their opening limits.

The AMI will be installed on to existing gantry infrastructure and shall include provisions for manned access to the rear of the AMI display panels.

The Contractor shall comply with the following requirement for gantry mounted AMIs:

- The AMI display panel shall be placed above at the centre over each running lane.
- The minimum vertical clearance required from AMI display panel to the road surface is 5.7m.
- All AMI shall be securely mounted to sustain the shock and vibration of the motorway environment.
- The Contractor shall be responsible for ensuring that all AMIs can be mounted to the existing and new AMI frames prior to the placement of any orders.
- The Contractor shall supply and install CMU's (Cable Marshalling Units), enclosures and connection units shall be mounted to the gantry structure where AMI is installed.

The Contractor shall submit details of the proposed cabling system to the Employer's Representative for review, within 20 working days of the Contract Date.

### 4.2 Mounting Requirements

The Contractor shall comply with all the requirements of this section. In all cases, it is the Contractor's responsibility to ensure that the new AMI will be properly installed and aligned on the existing structure arrangements.

The AMI display panel mounting arrangements shall include the facility to adjust and align the optical axes of the AMI display panel according to the road geometry.

Optical alignment of the AMI display panel in the vertical plane shall include an offset of  $-4^\circ$  down towards the direction of approaching traffic. The optical axis of the enclosure shall be adjustable from the offset position over the range  $+4^\circ$  ( $0^\circ$  Down Offset) to  $-2^\circ$  ( $-6^\circ$  Down Offset).

The Contractor shall ensure that the AMI is compatible with existing mounting structures (gantries and posts).

Typical AMI framework dimensions and framework sections sizes of existing gantries for the installation of proposed AMI's signage are scheduled in Table 2 with dimensions as illustrated in Figure 2 below. In accordance with Clause 1537.1AR of Volume A - Part 2: Works Specification, the Contractor shall carry out a dimensional survey of the existing gantries. The Contractor shall utilise dimensional information in the development of the AMI enclosure and mounting arrangement requirements to ensure compatibility with the existing infrastructure.

**Table 2 Typical AMI Framework Dimensions**

Frame Type	Framework Dimension (A x B)	Framework Section Size
A	1720 x 1325	80 x 80 x 6.3 SHS

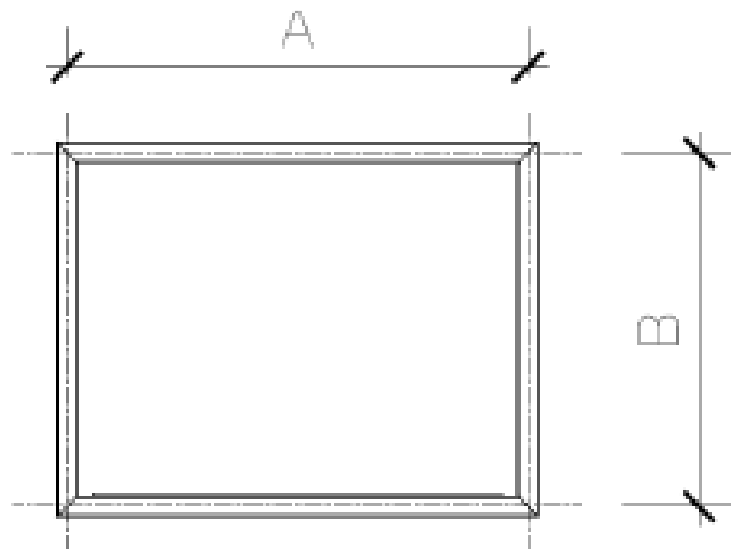

**Figure 2 Typical AMI Framework Dimensions Illustration**

All AMI shall be securely fixed in place and provide no opportunity for tools or equipment to fall to the roadside. For this purpose, the Contractor shall supply and install a custom made detachable closing off plate between the AMI display panel enclosure, the AMI frame on which the AMI brackets shall be mounted and the existing gantry structure. The closing off plate shall be provided along both the vertical sides and the bottom face (as required) of the AMI display panel enclosure and shall ensure that no gap larger than 5mm is present that would allow equipment or tools fall to the roadside.

The closing off plate shall be made of a suitable non-corrodible material and shall be fixed via mounting points provided on the existing frame or bracket. Details of mounting points on the AMI frame are included in on drawings included in the Background Information for information purposes. For the avoidance of doubt, drilling or welding onto the existing gantry structure shall not be permitted.

All bolts, with the exception of high strength friction-grip bolts, shall have locking nuts to prevent loosening by vibration.

All works that include studs, nuts, anchor plate and bolt frame, or a template, shall be designed in accordance with DN-STR-03018 - Design of Support Structures for Roadside Furniture.

Brackets and posts used shall be designed to take into account the maximum load, wind factor and the height at which equipment is required to operate.

The Contractor shall ensure that all brackets and posts used shall be installed in accordance with the manufacturer instructions.

Brackets and posts used shall be installed such that access and maintenance is not restricted.

Brackets and posts used shall be protected against environmental degradation (galvanised and painted).

The AMI structural assembly hardware and mounting brackets hardware shall be stainless steel or galvanised high-strength steel and shall be appropriately sized for the application.

All mountings, bolts, screws and any other fixing hardware shall be galvanised to EN ISO 1461:2022.

### **4.3 Co-ordination**

The Contractor shall participate in collaboration meetings with the NIMS Contractor, Equipment Maintenance Contractor and the Motorway Operations and Control Centre (MOCC) Operator to agree all matter to support the programming of works, joint responsibilities and the successful testing and commissioning of all AMI

The Contractor shall liaise with the Employer's Representative to confirm the mounting arrangements for each AMI.

### **4.4 Integration**

The Contractor shall collaborate with the NIMS Contractor and other contractors, to ensure the integration of all AMI provided, with the proposed NIMS and Associated Services.

The AMI shall be integrated with NIMS such that the AMI can receive and implement commands from NIMS in accordance with the AMI performance and communication requirements.

The AMI shall be integrated with NIMS such that messages can be automatically set on the signs by the VMS application of the NIMS in accordance with the AMI performance and communication requirements.

The AMI shall be integrated with NIMS and AFMS such that the AMI can report faults that occur and faults that have been cleared, to the NIMS and AFMS in accordance with the AMI performance and communication requirements.

At the Employer's Representative's request, the Contractor shall provide three AMIs and the number of controllers required to control 3 AMIs plus one extra controller and any required integration test units to support NIMS Interface development at the MOCC complex within 40 working days of Contract Date.

The Contractor shall liaise with the NIMS Contractor to integrate the AMI with NIMS and enable the activation processes as agreed during integration meetings.

The Contractor shall collaborate with the NIMS Contractors to implement configuration changes as required, including but not limited to:

- adding new sites;
- assigning or changing IP addresses; and,
- updating or amending GIS mapping data.

## **4.5 SAT & Commissioning**

The Contractor shall ensure that all AMI shall be submitted for approval of the Employer's nominated Engineer and shall be subject to tests to demonstrate compliance with this specification, EN 12966 and TR 1100.

The Contractor shall be responsible for testing and commissioning of all AMI in accordance with the requirements of Volume A - Part 4: Testing and Commissioning Specification.

## **5. SLIP ROAD SIGNAGE (SRS) AMIs**

### **5.1 General requirements**

The following chapter relates to the supply, installation and commissioning of the SRS AMI display panel at SRS sites.

The Contractor shall install each SRS AMIs on to the SRS supporting single post.

Each SRS site consist of a pair of SRS AMI display panels on opposite sides of the slip road.

The Contractor shall supply and install SRS AMI panels on the post at each SRS site.

All the functional and performance requirements in this specification shall apply also to SRS AMI, unless otherwise stated.

### **5.2 Design**

The Contractor shall be responsible for all mounting arrangements of each SRS AMI display unit to the single post provided others.

The Contractor shall supply and install all mounting arrangements.

The SRS AMI display panel shall be clearly legible from all lanes of the slip road from distances as defined in EN 12966 at all times and under all lighting conditions. The Contractor shall undertake the calculation to confirm the final legibility distances as per EN12966.

The SRS AMI display panel character sets, fonts, size and minimum dimensions shall be in accordance with the latest version of Traffic Signs Manual, Chapter 5 and Tables N.1, N.2 and N.3 of EN 12966 for Size Range C.

The SRS AMI display panel shall be capable of displaying any speed limits from 10-120 km/h in 5 km/h intervals.

The SRS AMI display panel shall be capable of displaying four full colour virtual flashing lanterns.

Each virtual flashing lantern shall be circular with diameter of minimum 160mm.

Each pair of virtual flashing lanterns shall alternately flash top and bottom.

The SRS AMI display panel shall be capable of displaying lanterns which shall not flash when displaying speed limits.

The SRS AMI display panel shall be capable of displaying numerical characters of two or three digits.

The height of the numerical character shall be at least 240mm.

The SRS AMI display panel shall have the option of displaying the characters 'km/h' below the numerical characters.

The minimum height of the 'km/h' characters shall be 100mm and they shall be centred below the numerals and within the Red Ring.

The SRS AMI display panel shall display Aspects (together with/without a steady-illuminated Red Ring and/or flashing lanterns) when requested by the AMI outstation controller.

The Red Ring shall have a maximum 760mm outer diameter.

There shall be at least 50mm space between the numerical character and the Red Ring.

The option of alternating Aspects to be displayed shall be allowed on the SRS AMI display panel.

The SRS AMI display panel shall be able to display Red 'X' to indicate closure of lane with side-to-side flashing lanterns.

The SRS AMI display panel shall be able to display wickets to indicate open/closed lanes with up and down flashing lanterns.

The SRS AMI display panel shall be able to display yellow arrow to the left with up and down flashing lanterns.

The SRS AMI display panel shall be able to display yellow arrow to the right with up and down flashing lanterns.

The SRS AMI display panel shall be able to display static symbols.

It shall be noted that due to the road geometry on the slip roads, some sites may not provide the designed visibility envelope. However, the performance of the SRS AMI display panel must comply with the requirement of EN 12966.

The AMI outstation controller shall sequence the operation of the virtual flashing lanterns such that they are synchronised for all sets of AMIs that are on the same gantry or either side of the slip road for SRS.

Figure 3 provides a representation of the post mounted SRS AMI display panel as well as the maximum external dimensions.

The SRS AMI display overall panel dimensions shall not exceed 1040mm x 1040mm as shown in Figure 3. The minimum dimension shall not be less than 940mm x 940mm.

The Contractor shall undertake design calculations for the optimal dimensions of the SRS AMI and submit it to the Employer's Representative for approval.

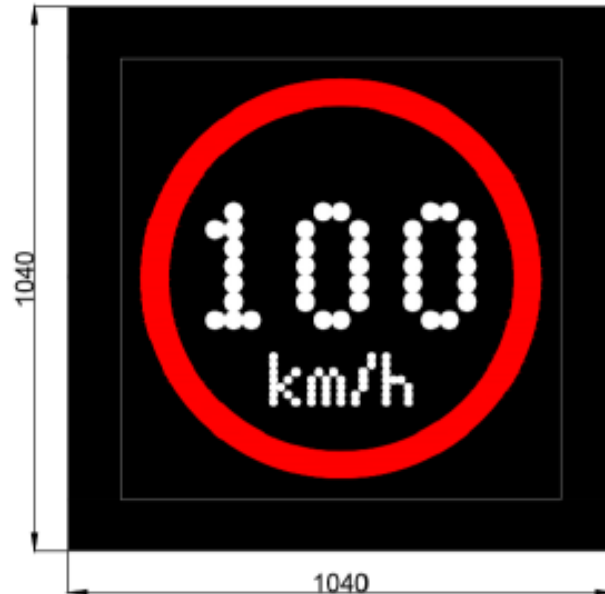

**Figure 3 SRS AMI Display Area and General Dimension**

### **5.3 Install**

The SRS AMI for SRS sites shall be installed on post (one on each side of the carriageway).

All SRS AMI shall be securely mounted to sustain the shock and vibration of the motorway environment.

The sign shall be secured to the post by a frame and bracket arrangement provided by the Contractor. The frame and bracket arrangement details shall be reviewed at the integration meeting.

The SRS AMI shall be capable of being fully maintained and repaired safely whilst remaining installed on its post. The Contractor shall confirm that the SRS AMI can be fully maintained whilst fixed to the post via the proposed SRS AMI frame and bracket arrangement.

A CMU is not required for SRS AMI.

Cables shall be routed to the base of the post from the SRS AMI via the inside of the SRS post.

The Contractor shall submit details of the proposed cabling system for the SRS AMI equipment to the Employer's Representative for review, within 20 working days of the Contract Date.

### **5.4 Mounting Requirements**

The Contractor shall comply with all the requirements of this section.

In all cases, it is the Contractor's responsibility to ensure that the new SRS AMI will be properly installed and aligned on post.

The SRS AMI display panel mounting arrangements shall include the facility to adjust and align the optical axes of the AMI display panel according to the road geometry.

The optical axis of the enclosure shall be adjustable over the range +4° up to -6° down Offset.

The Contractor shall ensure that the SRS AMI is compatible with new post.

The SRS AMI shall be mountable on a Post 75 mounting post in accordance with Highways England Specification MCE1109.

All bolts, with the exception of high strength friction-grip bolts, shall have locking nuts to prevent loosening by vibration.

All works that include studs, nuts, anchor plate and bolt frame, or a template, shall be designed in accordance with DN-STR-03018 - Design of Support Structures for Roadside Furniture and Eurocodes.

Brackets and frames used shall be designed to take into account the maximum loads, wind factor and the height at which equipment is required to operate.

The Contractor shall ensure that all brackets and frames used shall be installed in accordance with the manufacturer instructions.

Brackets and frames used shall be installed such that access and maintenance is not restricted.

Brackets and frames used shall be protected against environmental degradation (galvanised and painted).

The SRS AMI structural assembly hardware and mounting brackets hardware shall be stainless steel or galvanised high-strength steel and shall be appropriately sized for the application.

All mountings, bolts, screws and any other fixing hardware shall be galvanised to EN ISO 1461:2022.